

萬力電子有限公司
WANLI ELECTRONIC CO. LTD.

WTM057QDH01

規格書

APPROVED BY: _____

Table of Contents

Record of Revision.....	3
1. General Specifications	5
2. Input/Output Terminals	5
3. Absolute Maximum Ratings	6
4. Electrical Characteristics.....	6
4.1 Driving TFT LCD Panel.....	6
4.2 Driving Backlight.....	7
4.3 Block Diagram	8
5. Data input timing	9
5.1 SYNC mode.....	9
5.2 DE Mode.....	9
5.3 AC input characteristics.....	10
5.4 Timing Diagram.....	11
5.5 Power ON/OFF Sequence.....	12
6. Optical Characteristics	13
7. Environmental / Reliability Test	16
8. Mechanical Drawing.....	17
9. Packing Drawing	18
10. Precaution for Use of LCD Modules.....	22

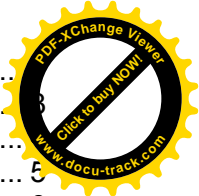
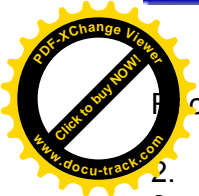

TIANMA CONFIDENTIAL

1. General Specifications

	Feature	Spec
Display Spec.	Size	5.7 inch
	Resolution	640(RGB) x 480
	Interface	RGB 18 bits
	Color Depth	262K
	Technology Type	a-Si
	Pixel Pitch (mm)	0.180x0.180
	Pixel Configuration	R.G.B. Vertical Stripe
	Display Mode	TM with Normally White
	Surface Treatment(Up Polarizer)	Anti-Glare(3H)
	Viewing Direction	6 o'clock
	Gray Scale Inversion Direction	12 o'clock
	LCM (W x H x D) (mm)	144.00x104.60x12.30
	Mechanical Characteristics	Active Area(mm)
With /Without TSP		Without TSP
Weight (g)		TBD
LED Numbers		21 LEDs

Note 1: Viewing direction for best image quality is different from TFT definition, there is a 180 degree shift.

Note 2: Requirements on Environmental Protection: Q/S0002

Note 3: LCM weight tolerance: $\pm 5\%$

2. Input/Output Terminals

CN1 pin assignment (Signal interface)

Connector type: 089H33-000100-G2-R (STARCON)

No	Symbol	I/O	Description	Comment
1	GND	P	Ground	
2	CK	I	Dot clock. Latch data at falling edge of CK.	
3	Hsync	I	Horizontal sync signal in SYNC mode. Pull low or floating when DE mode.	
4	Vsync	I	Vertical sync signal in SYNC mode. Pull low or floating when DE mode.	
5	GND	P	Ground	
6	R0	I	Red data (LSB)	
7	R1	I	Red data	
8	R2	I	Red data	
9	R3	I	Red data	
10	R4	I	Red data	
11	R5	I	Red data (MSB)	
12	GND	P	Ground	
13	G0	I	Green data(LSB)	
14	G1	I	Green data	
15	G2	I	Green data	
16	G3	I	Green data	
17	G4	I	Green data	
18	G5	I	Green data(MSB)	
19	GND	P	Ground	
20	B0	I	Blue data(LSB)	
21	B1	I	Blue data	
22	B2	I	Blue data	
23	B3	I	Blue data	
24	B4	I	Blue data	
25	B5	I	Blue data(MSB)	
26	GND	P	Ground	
27	ENAB	I	Data enable signal in DE mode. This pin must pull high when SYNC mode.	
28	VCC	P	Power supply	
29	VCC	P	Power supply	
30	R/L	I	Set horizontal scan direction: Low/NC: left to right; High: right to left	
31	U/D	I	Set vertical scan direction: High/NC: up to down; Low: down to up	
32	NC	-	No connection	
33	GND	P	Ground	

Note1: I/O definition:

I---Input O---Output P---Power/Ground

Note2: CN1 Matching FPC type: 33 pin, pitch: 0.5mm, height: 0.3mm.

Table 2.1 CN1 pin assignment

2.2 CN2 pin assignment (Backlight interface)

Connector type: SHLP-06V-S-B (JST)

No	Symbol	I/O	Description	Comment
1	AN1	P	LED Anode Terminal	Red
2	AN2	P	LED Anode Terminal	Red
3	AN3	P	LED Anode Terminal	Red
4	CA1	P	LED Cathode Terminal	White
5	CA2	P	LED Cathode Terminal	Blue
6	CA3	P	LED Cathode Terminal	Black

Note1: CN2 Matching Connector type: SM06B-SHLS-TF (JST)

Note2:P: Power/GND; I: input pin; I/O: input or output pin;

Table 2.2 CN2 pin assignment

3 Absolute Maximum Ratings

3.1 Driving TFT LCD Panel

GND=0V, Ta=25°C

Item	Symbol	Min	Max	Unit	Remark
Power Voltage	VCC	-0.5	5.0	V	
Input voltage	V _{IN}	-0.5	5.0	V	Note2
Operating Temperature	Top	-20	70	°C	Note1
Storage Temperature	Tst	-30	85	°C	Note1

Note1: The parameter is for driver IC (gate driver, source driver) only.

Note2: Signals include R0~R5, G0~G5, B0~B5, CK, Hsync, Vsync, Enable, R/L, U/D.

Table 3.1 absolute maximum rating

4 Electrical Characteristics

Driving TFT LCD Panel

GND=0V, Ta=25

Item	Symbol	MIN	TYP	MAX	Unit	Remark
Supply Voltage	VCC	3.00	3.30	3.60	V	
Permissible input ripple voltage	V _{RF}	-	-	100	mVp-p	VCC=3.3V
Input Signal Voltage	Low Level	V _{IL}	0	-	0.3xVCC	V
	High Level	V _{IH}	0.7xVCC	-	VCC	V
Common Electrode Driving Signal	VCOM	-	TBD.	-	V	Note1
Current of VCC Power supply	I _{VCC}	-	TBD.	TBD.	mA	Note2

Note1: For different LCM, the value may have a bit of difference.

Note2: To test the current dissipation, use "all Black Pattern".

Table 4.1 LCD module electrical characteristics

4.2 Driving Backlight

Ta=25°C

Item	Symbol	Min	Typ	Max	Unit	Remark
Series1 Forward Current	I ₁	-	25	-	mA	Note 1
Series2 Forward Current	I ₂	-	25	-	mA	
Series3 Forward Current	I ₃	-	25	-	mA	
Forward Voltage	V _{BL}	19.95	-	25.9	V	
Backlight Power Consumption	W _{BL}	-	1732.5	-	mW	
Life Time		25,000	50,000	-	Hrs	Note 3

Note 1: I_F is defined for one channel LED. There are total three LED channels in back light unit

Note 2: Optical performance should be evaluated at Ta=25°C only.

Note 3: If LED is driven by high current, high ambient temperature & humidity condition. The life time of LED will be reduced. Operating life means brightness goes down to 50% initial brightness. Typical operating life time is estimated data.

Table 4.2 LED backlight characteristics

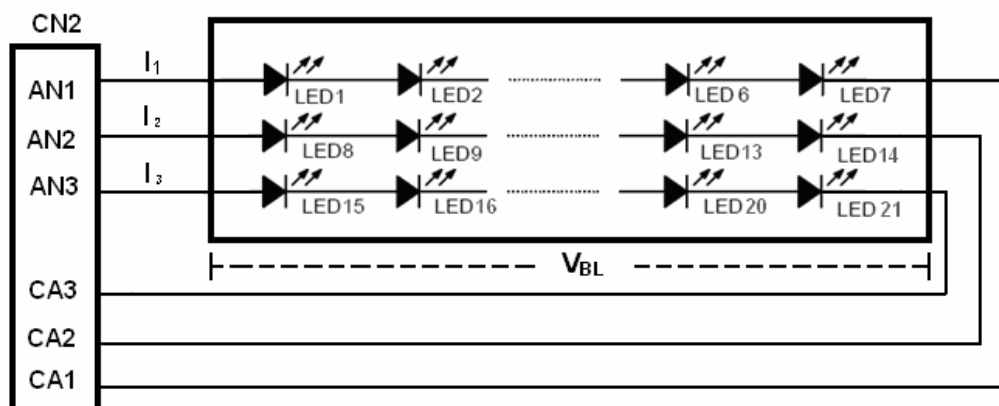
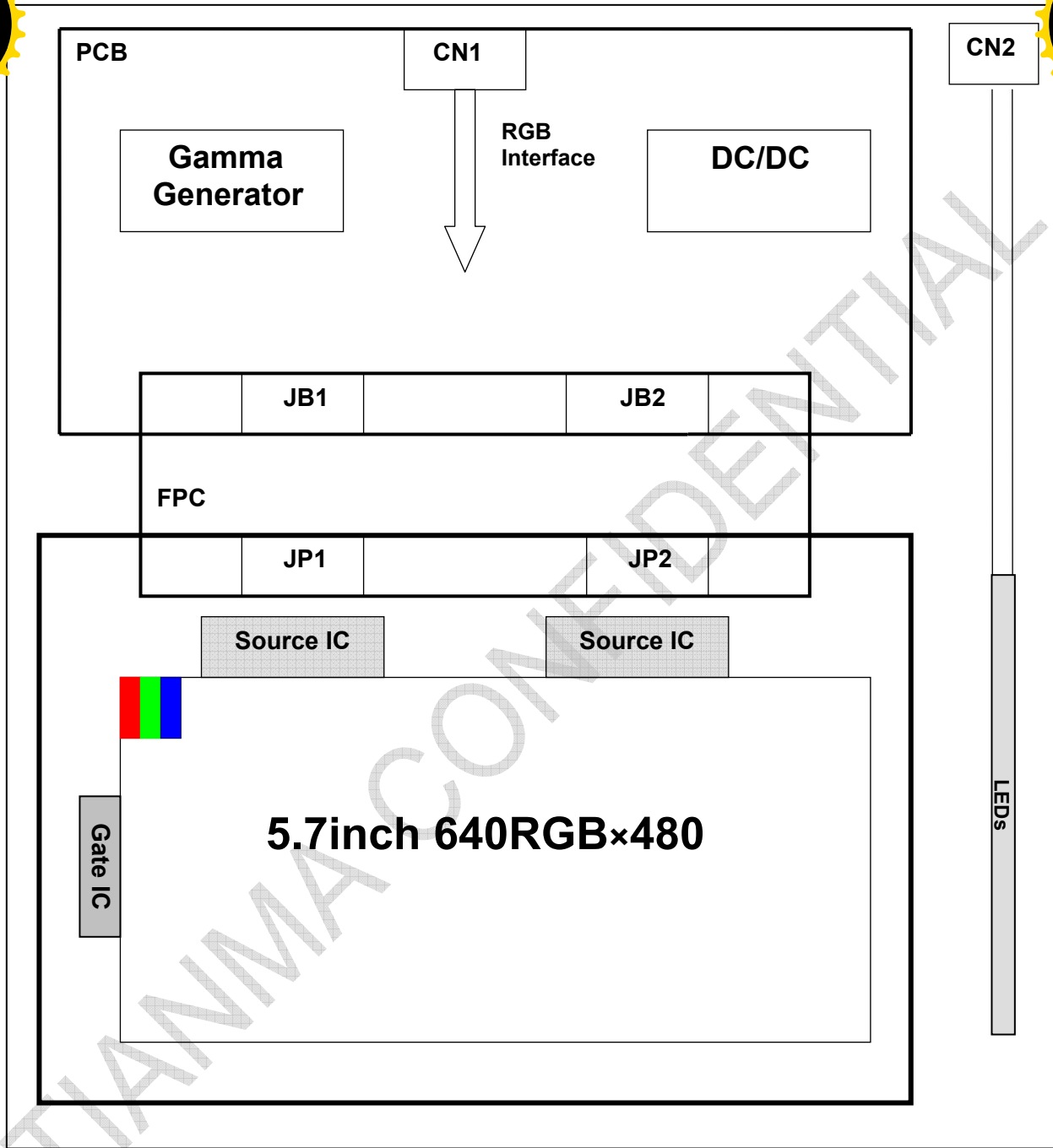
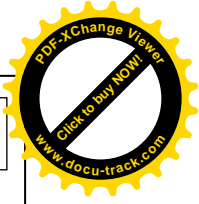

Figure 4.2 LED connection of backlight

4.3 Block Diagram



TIANMA CONFIDENTIAL

5. Data input timing

5.1 SYNC mode

Parameter	Symbol	Symbol	Min	Typ	Max	Unit
CK	Dotclk frequency	Fclk	24.8	25.2	34.2	MHz
	Dotclk cycle	Tclk	29.24	39.68	40.32	ns
Hsync	Horizontal display area	Thd	640	640	640	Tclk
	1 horizontal line	Th	800	800	1000	Tclk
	Hsync pulse width	Thpw	1	-	-	Tclk
	Horizontal blank	Thb	144	144	144	Tclk
	Horizontal front porch	Thfp	16	16	216	Tclk
Vsync	Frame rate	-	-	60	-	Hz
	Vertical display area	Tvd	480	480	480	Th
	Vsync period time	Tv	516	525	570	Th
	Vsync pulse width	Tvpw	1	-	-	Th
	Vsync blank	Tvb	35	35	35	Th
	Vsync front porch	Tvfp	1	10	55	Th

Table 5.1 SYNC mode input timing

5.2 DE mode

Description		Symbol	Min	Typ	Max	Unit
CK	Dot clock frequency	Fclk	24.8	25.2	34.2	MHz
Horizontal section	Horizontal total	Th	800	800	1000	Tclk
	H Total blank	Thb+Thfp	160	160	360	Tclk
	Valid Data Width	Thd	640	640	640	Tclk
Vertical section	Frame rate	-	-	60	-	Hz
	Vertical total	Tv	516	525	570	Th
	V total blank	Tvb+Tvfp	36	45	90	Th
	Valid Data Width	Tvd	480	480	480	Th

Note: The LCM could auto-detect which mode is working.

Table 5.2 DE mode input timing

5.3. Timing Diagram

5.3.1 Vertical Input Timing

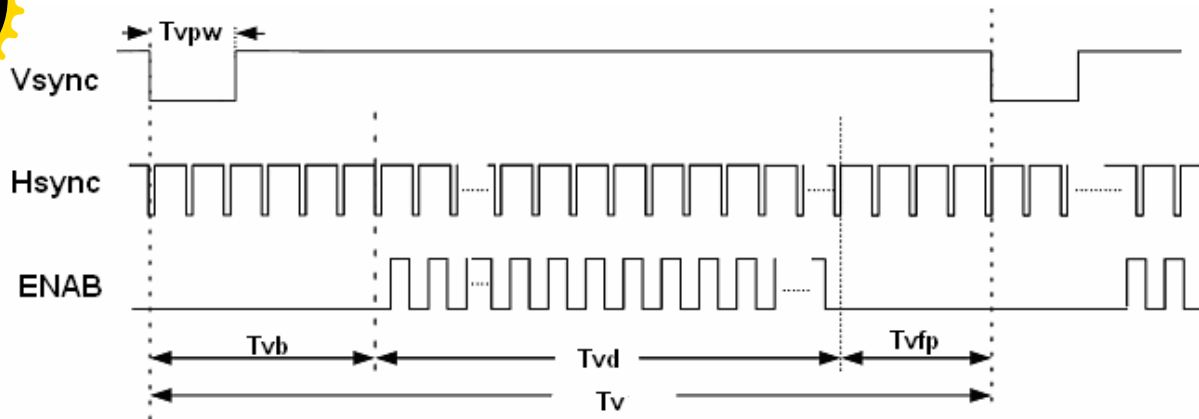

Figure 5.3.1 Vertical input timing

5.3.2 Horizontal Input Timing

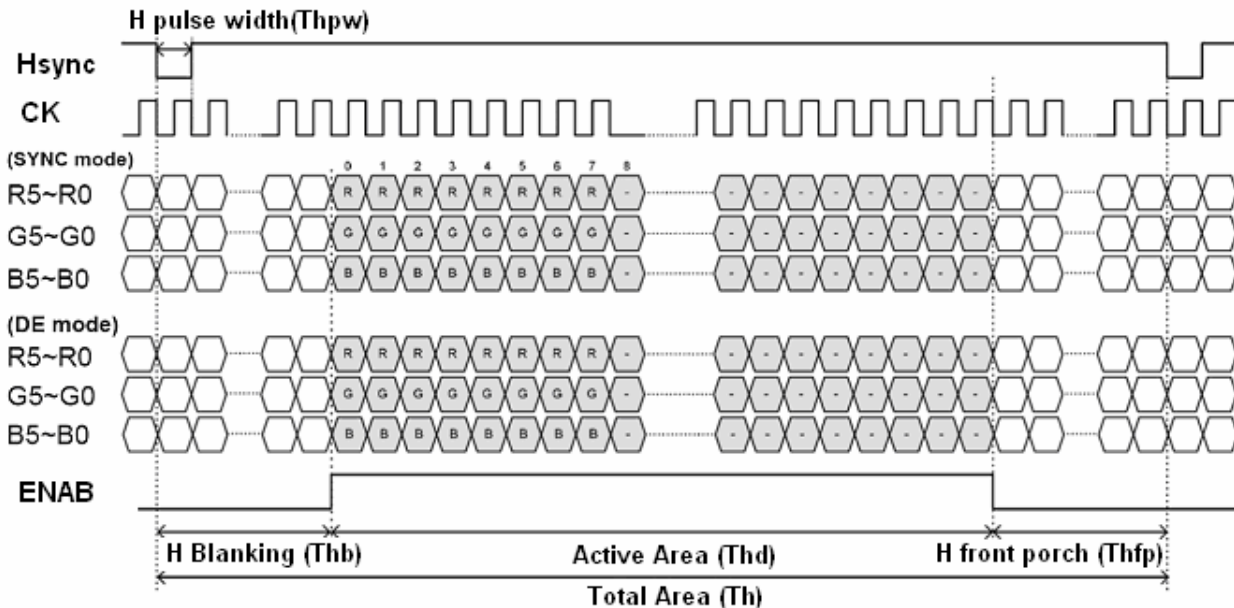

Figure 5.3.2 Horizontal input timing

5.4 AC input characteristics

(VCC=3.3V, GND=0V, Ta=25°C)

Parameter	Symbol	Min	Typ	Max	Unit	Conditions
CK pulse duty	Tcwh	40%	50%	60%	Tclk	
Vsync setup time	Tvst	8	-	-	ns	
Vsync hold time	Tvhd	8	-	-	ns	
Hsync setup time	Thst	8	-	-	ns	
Hsync hold time	Thhd	8	-	-	ns	
Data setup time	Tdsu	8	-	-	ns	Rn, Gn, Bn to Dotclk
Data hold time	Tdhd	8	-	-	ns	Rn, Gn, Bn to Dotclk
ENAB setup time	Tesu	8			ns	

Table 5.4 AC input characteristics

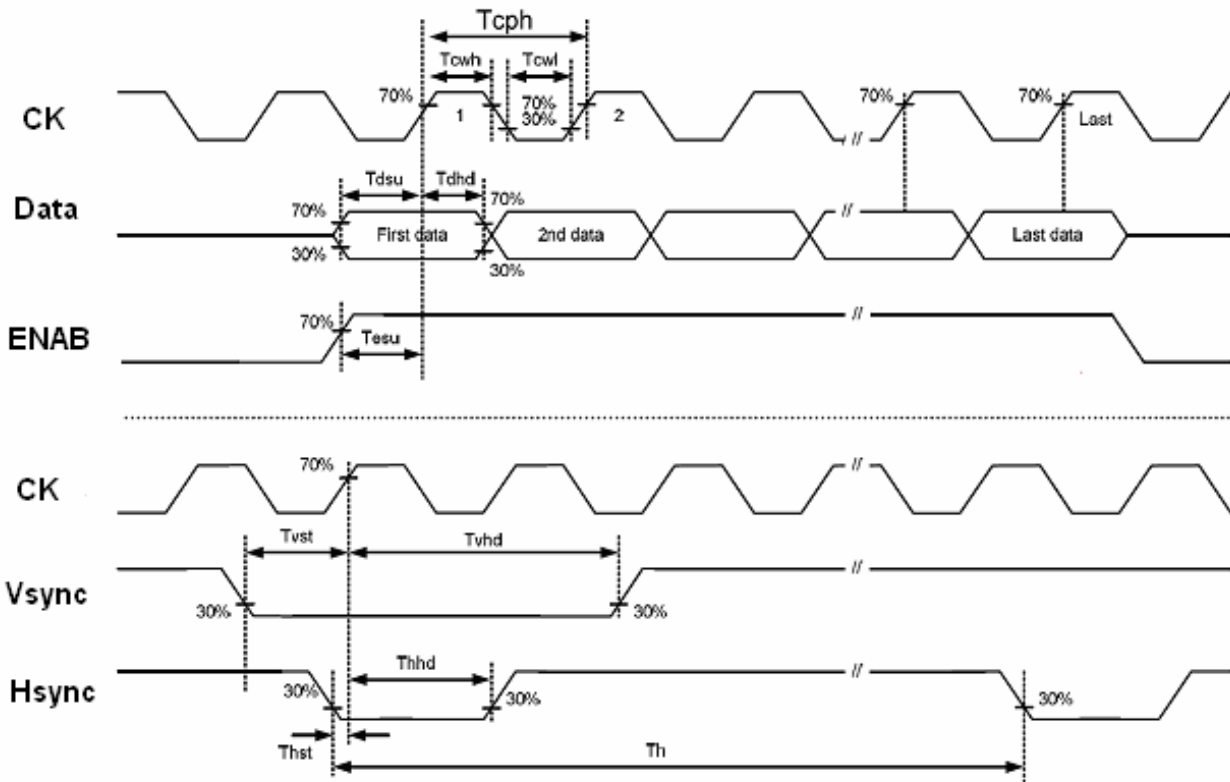

Figure 5.4 AC input characteristics

5.5 Power ON/OFF Sequence

Item	Symbol	Min	Typ	Max	Unit	Remark
VCC 3.0V to signal starting	Tp1	5	-	50	ms	
Signal starting to backlight on	Tp2	50	-	-	ms	
Signal off to VCC 3.0V	Tp3	0	-	50	ms	
Backlight off to signal off	Tp4	50	-	-	ms	

Table 5.5 Power on/off sequence

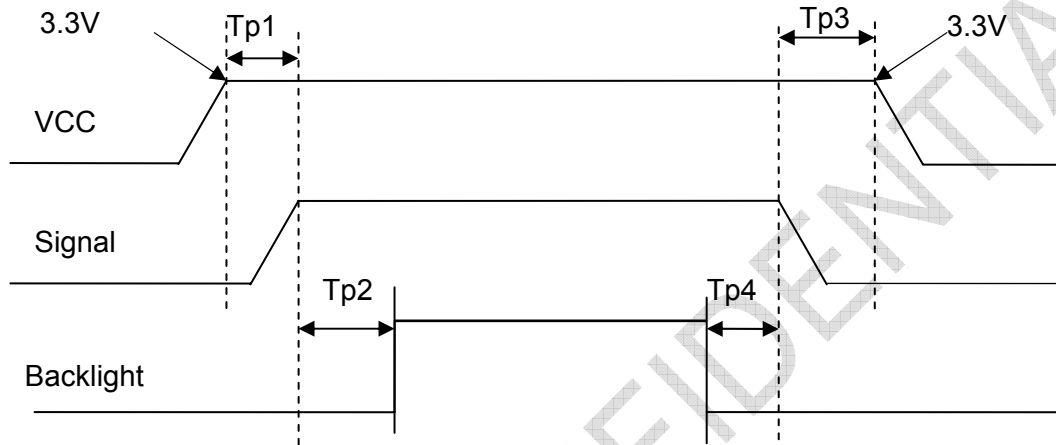

Figure 5.5 Power on/off sequence

TIANMA CONFIDENTIAL

6. Optical Characteristics

Item		Symbol	Condition	Min	Typ	Max	Unit	Remark		
View Angles		θT	$CR \geq 10$	60	70	--	Degree	Note 2		
		θB		50	60	--				
		θL		60	70	--				
		θR		60	70	--				
Contrast Ratio		CR	$\theta=0^\circ$	400	500	--		Note1、Note3		
Response Time		T_{ON}	$25^\circ C$	--	20	30	ms	Note1		
		T_{OFF}						Note4		
Chromaticity		White	Backlight is on					Note5 Note1		
									x	TBD
		y							TBD	
		Red							x	TBD
									y	TBD
		Green							x	TBD
									y	TBD
		Blue							x	TBD
y	TBD									
Uniformity		U		75	80	--	%	Note1、Note6		
NTSC				--	50	--	%	Note 5		
Luminance		L		320	400	--	cd/m^2	Note1、Note7		

Test Conditions:

1. $I_F = 25mA$ (one channel), $V_F = 23.1V$, the ambient temperature is $25^\circ C$.
2. The test systems refer to Note 1 and Note 2.

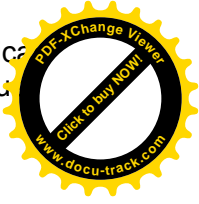

Note 1: Definition of optical measurement system.

The optical characteristics should be measured in dark room. After 5 Minutes operation, the optical properties are measured at the center point of the LCD screen. All input terminals LCD panel must be grounded when measuring the center area of the panel.

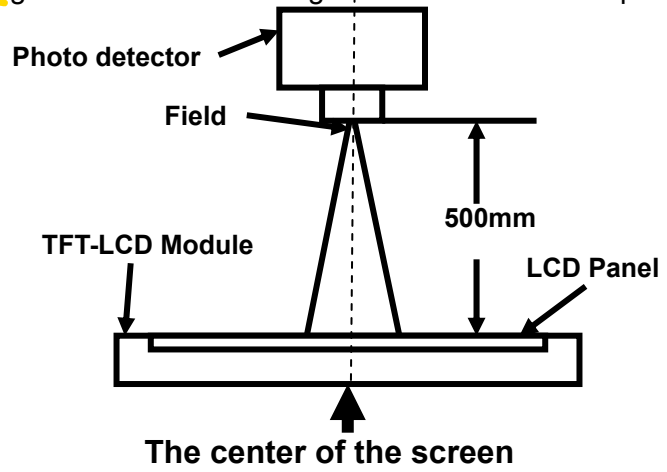

Item	Photo detector	Field
Contrast Ratio	SR-3A	1°
Luminance		
Chromaticity		
Lum Uniformity		
Response Time	BM-7A	2°

Note 2: Definition of viewing angle range and measurement system.

viewing angle is measured at the center point of the LCD by CONOSCOPE(ergo-80).

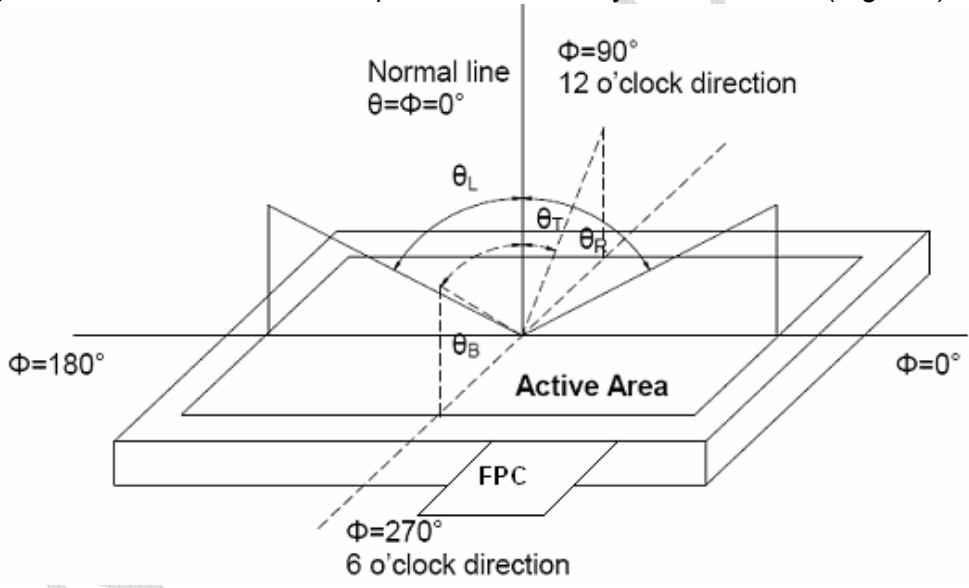

Note 3: Definition of contrast ratio

$$\text{Contrast ratio (CR)} = \frac{\text{Luminance measured when LCD is on the "White" state}}{\text{Luminance measured when LCD is on the "Black" state}}$$

“White state”: The state is that the LCD should drive by V_{white} .

“Black state”: The state is that the LCD should drive by V_{black} .

V_{white} : To be determined V_{black} : To be determined.

Note 4: Definition of Response time

The response time is defined as the LCD optical switching time interval between “White” state and “Black” state. Rise time (T_{ON}) is the time between photo detector output intensity changed from 90% to 10%. And fall time (T_{OFF}) is the time between photo detector output intensity changed from 10% to 90%.

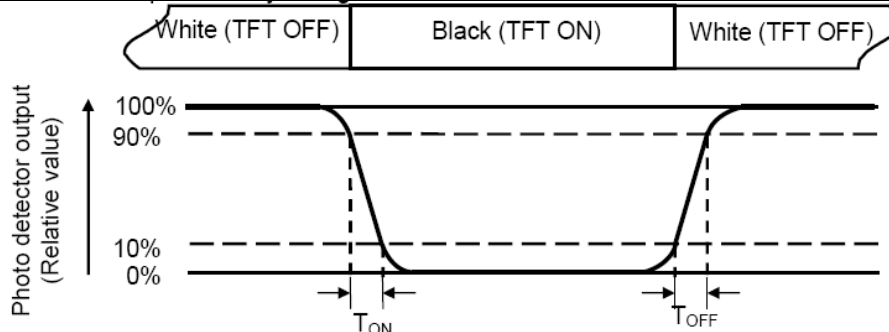
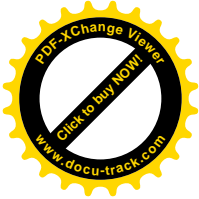
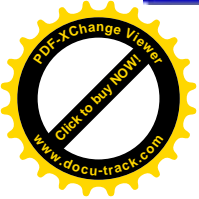

Note 5: Definition of color chromaticity (CIE1931)
Color coordinates measured at center point of LCD.

Note 6: Definition of Luminance Uniformity

Active area is divided into 9 measuring areas (Refer Fig. 2). Every measuring point is placed at the center of each measuring area.

$$\text{Luminance Uniformity (U)} = L_{\min} / L_{\max}$$

L-----Active area length W----- Active area width

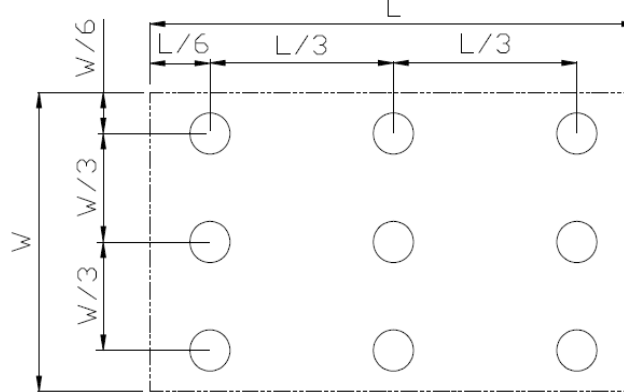

L_{\max} : The measured Maximum luminance of all measurement position.

L_{\min} : The measured Minimum luminance of all measurement position.

Note 7: Definition of Luminance:

Measure the luminance of white state at center point.

TIANMA

7. Environmental / Reliability Test

No	Test Item	Condition	Remarks
1	High Temperature Operation	Ts = +70°C, 240 hours	IEC60068-2-2 GB2423.2-89
2	Low Temperature Operation	Ta = -20°C, 240 hours	IEC60068-2-1 GB2423.1-89
3	High Temperature Storage	Ta = +85°C, 240 hours	IEC60068-2-2 GB2423.2-89
4	Low Temperature Storage	Ta = -30°C, 240 hours	IEC60068-2-1 GB2423.1-89
5	Storage at High Temperature and Humidity	Ta = +60°C, 90% RH max, 240 hours	IEC60068-2-3 GB/T2423.3-2006
6	Thermal Shock (non-operation)	-20°C 30 min~+60°C 30 min, Change time:5min, 100 Cycle	IEC60068-2-14 GB2423.22-87
7	ESD	C=150pF,R=330Ω,5point/panel Air:±15Kv,5times; Contact:±8Kv,5times (Environment:15°C~35°C, 30%~60%.86Kpa~106Kpa)	IEC61000-4-2 GB/T2423.5-1995
8	Vibration Test	Frequency range:10~200Hz Stroke:1.5mm Sweep:10Hz~200Hz~10Hz 30 minutes for each direction of X.Y.Z. (1.5 hours for total)	IEC60068-2-6 GB/T2423.10-1995
9	Mechanical Shock (Non Op)	Half Sine Wave 50G 20ms, ±X,±Y,±Z 3times for each direction	IEC60068-2-27 GB/T2423.5-1995
10	Package Drop Test	Height:80cm, 1corner,3edges,6surfaces	IEC60068-2-32 GB/T2423.8-1995
11	Package Vibration Test	Random Vibration: 0.015G*G/Hz for 5-200Hz, -6dB/Octave from 200-500Hz 2 hours for each direction of X,Y,Z (6 hours for total)	IEC60068-2-34

Note1: Ts is the temperature of panel's surface.

Note2: Ta is the ambient temperature of samples.

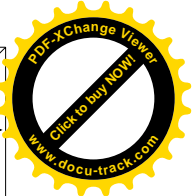

3. Mechanical Drawing

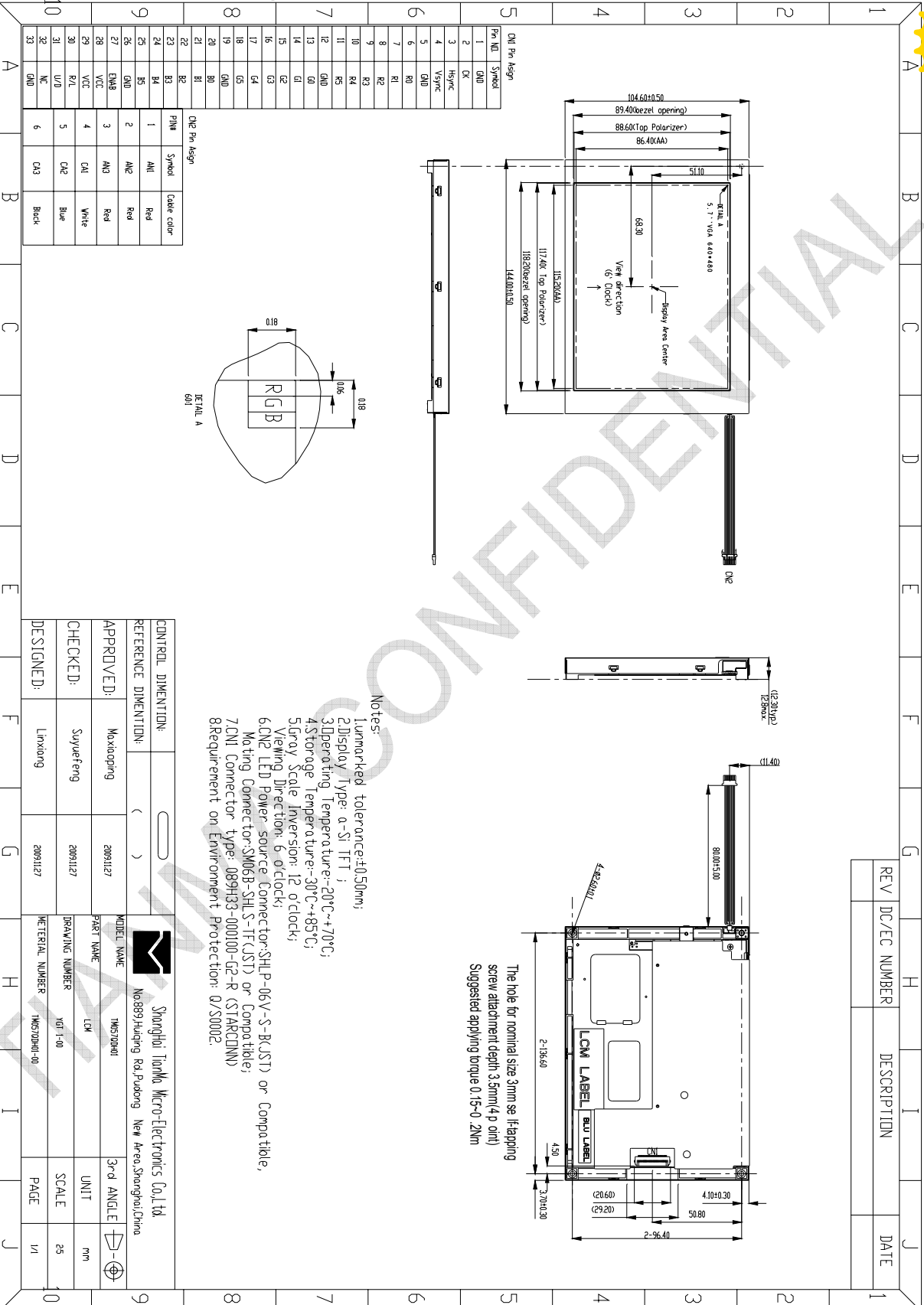

REV	DC/EC NUMBER	DESCRIPTION	DATE

CONTROL DIMENTION:	()	MODEL NAME	Shanghai TianMa Micro-Electronics Co., Ltd.
REFERENCE DIMENTION:	()	PART NAME	No.889Jiangsu Rd., Pudong New Area, Shanghai, China
APPROVED:	Maxiaoping	DRAWING NUMBER	104
CHECKED:	Suyuefeng	UNIT	3° or ANGLE
DESIGNED:	Linkang	SCALE	mm
	20091127	PAGE	25
	20091127		1/1

The hole for nominal size 3mm se-flapping screw attachment depth 3.5mm(4p orbit) Suggested applying torque 0.15~0.2Nm

9. Packing Drawing

Packaging Material

No	Item	Model(Material)	Dimensions (mm)	Unit Weight (Kg)	Quantity	Remarks
1	LCM module	TM057QDH01-00	144X104.6X12.3	TBD	40	
2	Partition_1	Corrugated paper	513X333X215	1.388	1	
3	Anti-static Bag	PE	180X165X0.05	0.001	40	Anti-static
4	Dust-Proof Bag	PE	700X530	0.06	1	
5	Partition_2	Corrugated Paper	505X332X4.0	0.098	2	
6	Corrugated Bar	Corrugated paper	513X110×31	0.048	4	
7	Carton	Corrugated paper	530X350X250	1.12	1	
8	Total weight	TBD				

Note: Packaging Specification and Quantity

Module quantity in a carton: 20pcs(per row)x2(per column)= 40pcs

9.2 Packing Instruction

9.2.1 Single LCM's packing

Insert the LCM into the anti-static bag as follow:

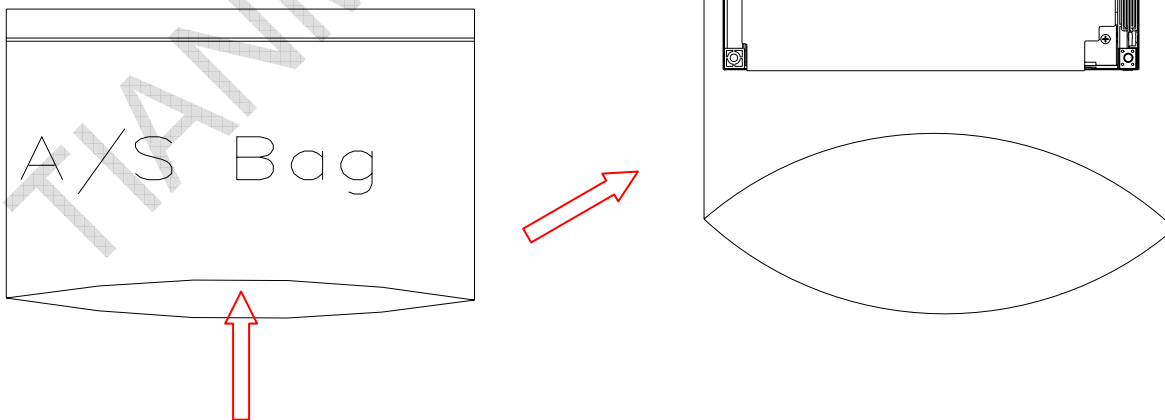

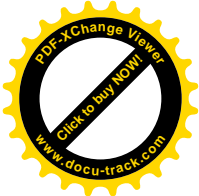
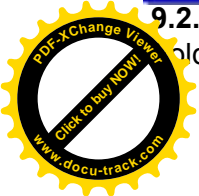

9.2.2 Anti-static bag's packing

Hold the anti-static bag on the back of the LCM as follow, then fasten it by beauty-grain tape.

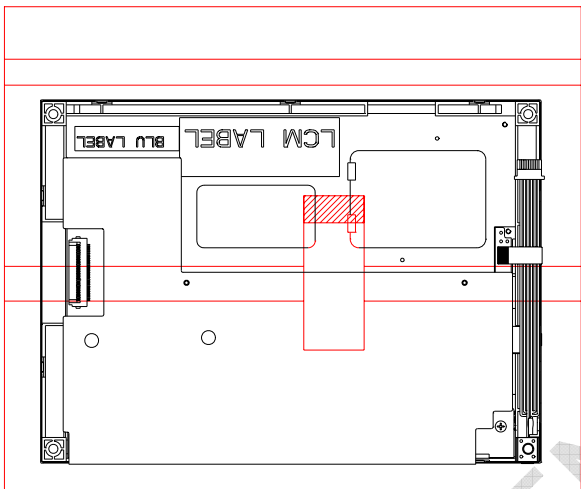

9.2.3 Dummy Packing assembly

A. Put the partition_2 in the anti-dust bag, showing as follow :

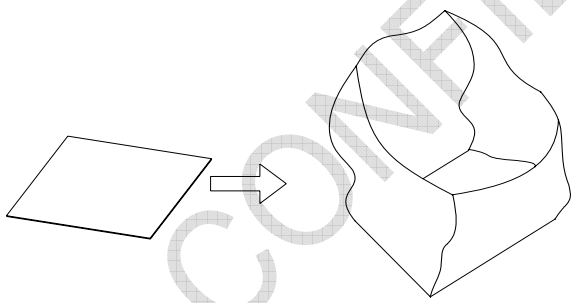

B. Assemble CORRUGATED BAR and partition_1 as follow

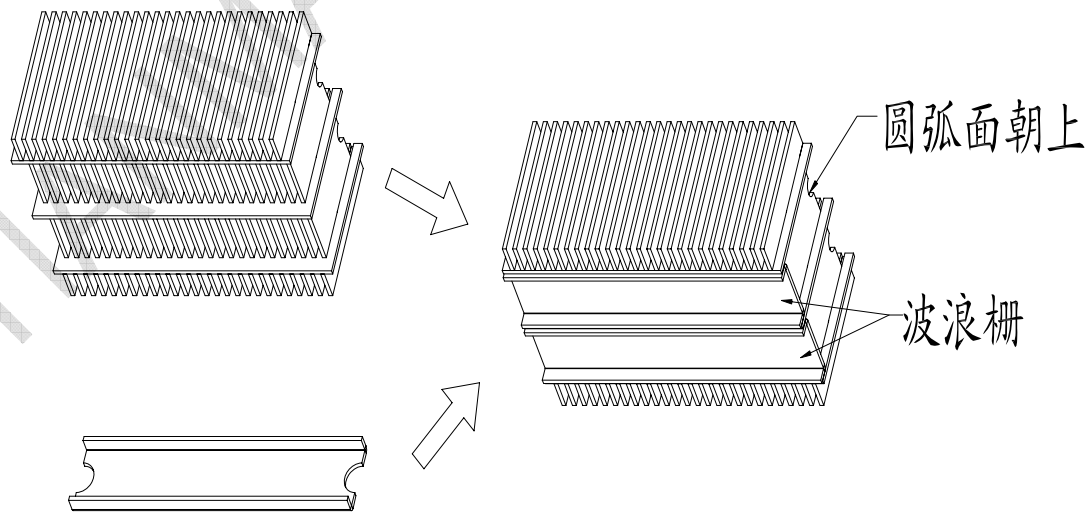

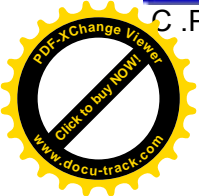

C. Put the assembly in STEP B in anti-dust bag, then assemble the assembly and carton as follow:

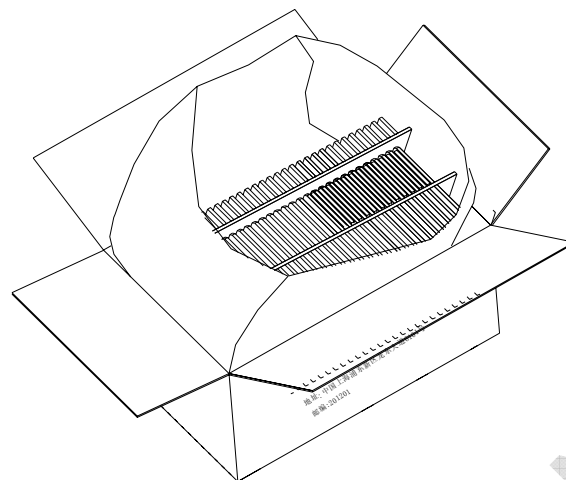
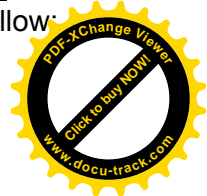

D. Insert the LCM into the assembly with the lightbar cables up:

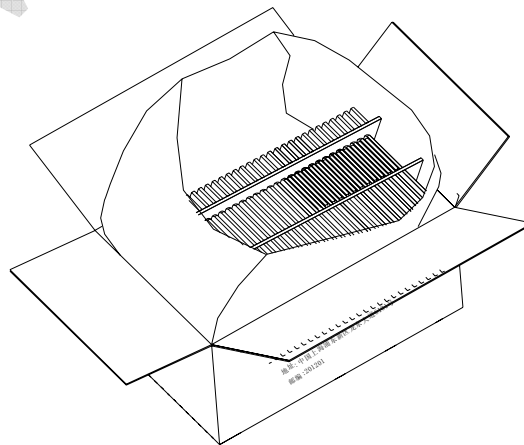
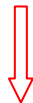
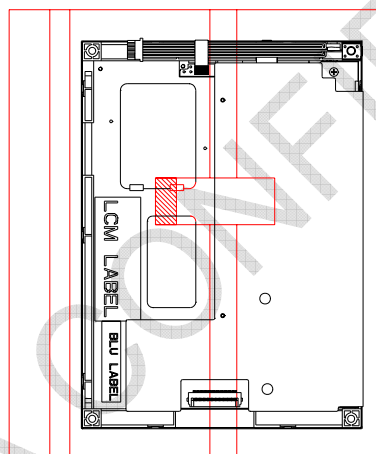

TIANMA CONFIDENTIAL

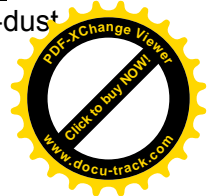
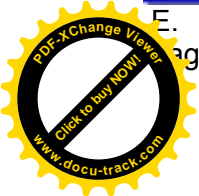

E. Put two CORRUGATED bars in partition_1, then cover them with partition_2, finally seal the anti-dust bag:

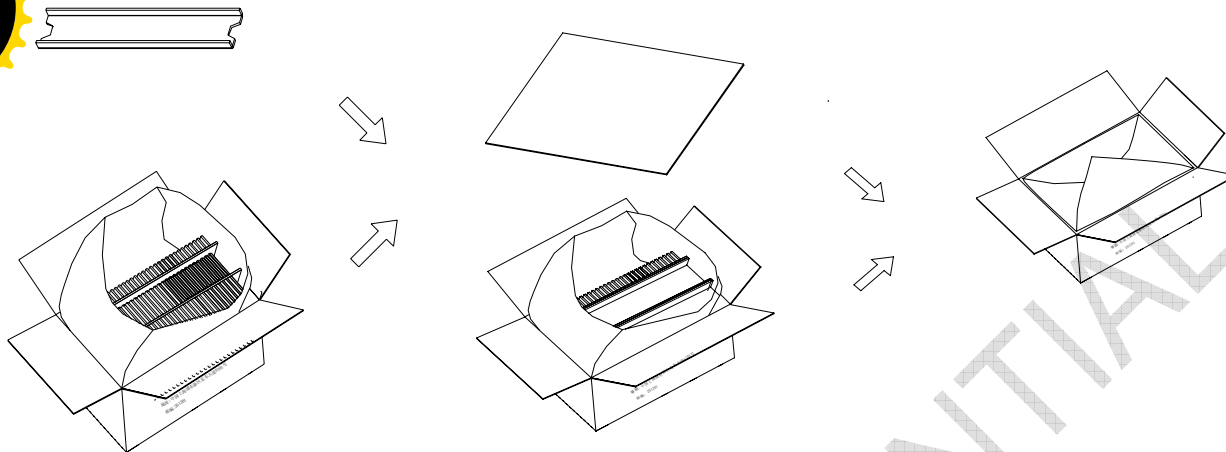

F. Sealing the carton:

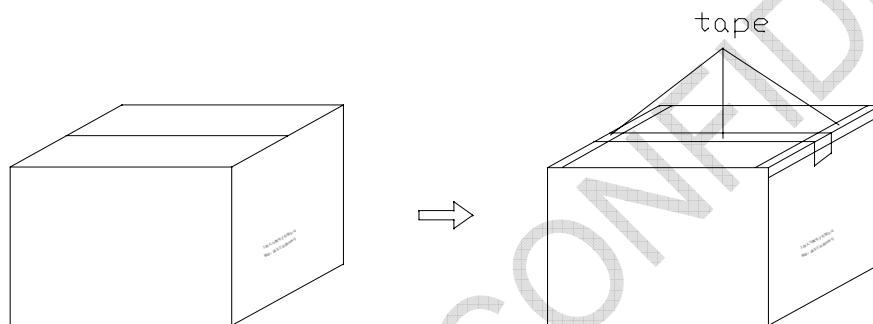

9.2.4 Stacking layout

Total quantity of cartons in a board=2 *3/per layer *5 layers

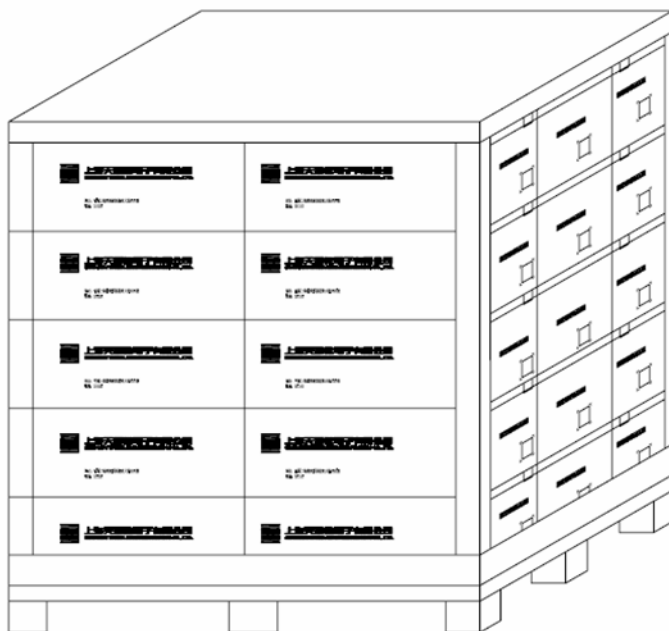

10. Precautions for Use of LCD Modules

10.1 Handling Precautions

- 10.1.1 The display panel is made of glass. Do not subject it to a mechanical shock by dropping from a high place, etc.
- 10.1.2 If the display panel is damaged and the liquid crystal substance inside it leaks out, be sure not to get any in your mouth, if the substance comes into contact with your skin or clothes, promptly wash it off using soap and water.
- 10.1.3 Do not apply excessive force to the display surface or the adjoining areas since this may cause the color tone to vary.
- 10.1.4 The polarizer covering the display surface of the LCD module is soft and easily scratched. Handle this polarizer carefully.
- 10.1.5 If the display surface is contaminated, breathe on the surface and gently wipe it with a soft dry cloth. If still not completely clear, moisten cloth with one of the following solvents:
- Isopropyl alcohol
 - Ethyl alcohol

Solvents other than those mentioned above may damage the polarizer. Especially, do not use the following:

- Water
 - Ketone
 - Aromatic solvents
- 10.1.6 Do not attempt to disassemble the LCD Module.
- 10.1.7 If the logic circuit power is off, do not apply the input signals.
- 10.1.8 To prevent destruction of the elements by static electricity, be careful to maintain an optimum work environment.
- 10.1.8.1 Be sure to ground the body when handling the LCD Modules.
- 10.1.8.2 Tools required for assembly, such as soldering irons, must be properly ground.
- 10.1.8.3 To reduce the amount of static electricity generated, do not conduct assembly and other work under dry conditions.
- 10.1.8.4 The LCD Module is coated with a film to protect the display surface. Be care when peeling off this protective film since static electricity may be generated.

10.2 Storage precautions

10.2.1 When storing the LCD modules, avoid exposure to direct sunlight or to the light of fluorescent lamps.

10.2.2 The LCD modules should be stored under the storage temperature range. If the LCD modules will be stored for a long time, the recommend condition is:

Temperature : 0°C ~ 40°C Relatively humidity: ≤80%

10.2.3 The LCD modules should be stored in the room without acid, alkali and harmful gas.

10.3 Transportation Precautions

10.3.1 The LCD modules should be no falling and violent shocking during transportation, and also should avoid excessive press, water, damp and sunshine.